

A Coranto with a Diagram

Priska Frank

While studying material concerning dancing at the Inns of Court, my main sources were six manuscripts, known to dance scholars as 'Inns of Court manuscripts,' since they all seem to originate from this institution.

These six so-called manuscripts of the Inns of Court cover a period of one century (1570-1670), and parts of these manuscripts deal with dances which were danced at the Inns by the students. All six manuscripts give descriptions of the so-called measures; slow, stately dances, mostly pavans and allemands. In some of the manuscripts several faster dances, which followed the slow ones, are included as well². Several galliards, the cinque pace, branles, Lavolta, two corantos, the Spanioletta and various other dances can be found.

One of the manuscripts, Rawl.864³, dated around 1630, but probably written a few years later, contains a description of several measures and, on a separate sheet⁴, two dances accompanied by two diagrams⁵. These two dances are quite unique; not just because of these diagrams, but also because of their vocabulary which differs very much from any other source. This is the only one of the six manuscripts which contains diagrams. Up to now no-one seems to have dealt with these diagrams, or at least published them. The first dance does not have a title and is very complicated: so far I have not been able to make a reasonable connection between the description of the steps and the diagram. But let this not discourage anyone interested from making an attempt themselves.

The second dance is called **the first Coranto**, and again consists of a description of steps and a diagram with numbers (this is also the case with the previous dance). The manuscripts read as follows:

"2 ffained mounts, a hop and a chace, a hop, a bow forwards

2 a winde and a chace back, to the left hand side waies: a hop and a lene back, a hop to the right with a chace

3 a hop and a lene to the left hand

4 a wind and a chace with a hop and a lene round with your face to the beginning

5 then a hop and a chace forward with a hop and a leane

6 a wind and a chace back to the left hand

7 a hop and a pas back, a hop and a chace

8 and a hop and a lene round

9 hop hop and wind a chace, a halfe caper a close and a caper and end and with this close draw smartly your leg and do yr honour.

10"

The second line under number 9 indicates exactly the movement made by the man when he is doing an honour. Most of the commas in the text are editorial.

I would like to emphasize that the numbers given in the drawing (see figure) are provided in the manuscript, but those in the text are a suggestion of mine.

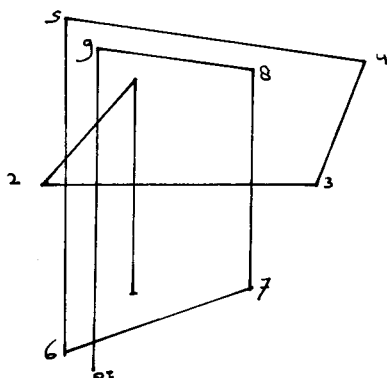

My explanation of the unusual terms (see *Oxford English Dictionary*) is as follows:

— fained: see Italian "finto"⁶, feigned, pretended, lazy: a step in place

— mounts: to mount is also the act of rising (like a bird): jump

— chace: chase, to run with speed, hurry: fast/large step⁷

— lene/bow: it is not clear what the manuscript reads, a bow would be obvious, a lene might mean anything ("leave" i.e. congè?)

— wind: move in a curve, especially in a specified direction

— draw: also withdraw, and draw **back**

This unique vocabulary seems to be restricted to these two dances and is not known elsewhere⁸.

Cunningham⁹ mistakenly assumes that these two dances are solo dances, an opinion based on the single line diagrams. But I do not agree with this; other known coranto choreographies from the period are for one man and one woman. According to M. Wood¹⁰ there was a tendency at the end of the 16th century to introduce figure dancing into the coranto; this seems to be confirmed by this dance.

If this dance description originates from the Inns of Court, **The first Coranto** may well indicate that it was the first of a set of corantos following the measures.

I hope that, by publishing my provisional findings in connection with this dance, I may encourage other people to continue the investigations and possibly find a way to fit this dance description to music.

Notes

1 Oxford, Bodleian Library: Rawl. Poet. 108
Rawl. D 864

Douce 280

London, British Library: Harley 367

Royal College of Music: Manuscript 1119

Inner Temple: Miscellaneous manuscript
vol. XXVII

2 The so-called Revels (dancing sessions at the Inns of Court) consisted of, first, a section of slow dances, the **measures**, followed by faster dances, the **post-revels** or **brawls**.

3 Rawl. D 864: "The Ashmole" manuscript: "A cople of the oulde measures" written by Elias Ashmole, on page 199 r+v.

4 pp. 203-204 v.

5 These diagrams are some of the earliest known; the use of diagrams showing the pattern of the dance on the floor, came really into fashion in the 18th century.

6 C. Negri, **Le Gratie d'Amore** (Milan, 1602), p. 107 regola 8 "seguito grave finto".

7 See also F. Caroso, **Nobiltà dei Dame** (Venice, 1600, rule 56 "Ricacciate").

8 Rosalind King (Queen Mary College, London), at home both in English and dance descriptions, has confirmed my beliefs.

9 J. P. Cunningham, **Dancing in the Inns of Court** (London, 1965), deals with the six Inns of Court manuscripts and provides some background information. His approach is rather too general and there are many mistakes. Although it would have been rather appropriate, the diagrams are not included.

10 M. Wood, **Historical dances** (London, 1964), p. 77.



The first round

234

half

forward

2. forward round a hop and a step a hop and a bow,
 a wind on a side a bow to the left hand side with a hop
 and a bow with a hop to the right hand with a step
 a hop and a bow to the left hand, a wind and a step with
 a hop and a bow round with a hop and a bow
 a hop and a step forward with a hop and a bow
 a step back to the left hand a hop and a bow back, a hop
 and a step and a hop and a bow round with a hop and a bow
 a half a step a step and a step and a step

| | | | | |
|----------|---|---------|---|---|
| 1 | 2 | 3 | 4 | 5 |
| BODLEIAN | | LIBRARY | | |

forward

2. forward round a hop and a step a hop and a
 bow with a step to the right hand a round and a
 step a hop and a bow round to the beginning a hop
 and a bow to the left hand back with a step and
 a bow all so, a hop and a step to the right hand and a
 half a step over and back with a hop and a bow
 2. forward round a hop and a bow round as you be-
 gin a hop and a step and a bow with a hop and a bow
 to the right hand with a step a hop and a bow forward
 a hop and a bow with a step to the right hand
 round and a step a hop and a bow round with a hop
 and a bow the first to the left the other to the right
 and a step a half a step a step and a step



Ms. Russl. D. 864, fol. 204r

Ms. Russl. D. 864, fol. 203r